



BULLY DOG



TRIPLE DOG E³ DIESEL downloader

The Triple Dog E3 Diesel downloader is designed to provide added performance and economy. Everything packed into this product, from the engine tuning to the speed limiter function is designed to help users achieve better fuel economy and usable performance gains. This product was also designed to accommodate a lower price point, the price has been significantly reduced from our regular Triple Dog Product line. The Triple Dog E3 carries one engine tune to make things easy for the end user. That one engine tune is adjustable On-The-Fly, so the user can toggle back and forth between that tune and their stock power level, a matter of convenience. The Triple Dog E3 will work on over 20 different vehicle applications including Dodge, Ford, GM diesel pickups and the Ford Excursion, see our vehicle application chart on the next page for full details.

Engine Tuning

The engine tuning options below describe the engine tuning available through the Triple Dog E3 diesel

- **Stock:** Choosing the Stock engine tune will result in no change to engine horsepower output. All other downloader features can still be accessed if the Stock engine tune is chosen.
- **Tow/Economy:** This tune can be used for everyday driving and towing. Dynamometer testing results have shown a 50 horsepower and 100+ lbs. ft. of torque increase in rear wheel horsepower.

TRIPLE DOG E3 DIESEL

VEHICLE APPLICATIONS	Hp/Torque	PART #	MSRP	Packaging Weight	Packaging Dimension	UPC Code
Triple Dog E3 Diesel Downloader	50+ hp/100+ ft.-lbs	40505	\$439	2lbs.	10.5X8.5X3	681018405058

POWER PUP DOWNLOADER FEATURES

Over 20 different vehicle applications

Between Dodge, Ford, GM, pickups and SUVs the Triple Dog E3 works on over 20 of them. Check out the vehicle application chart on the next page to see all of the applications that currently work on the E3.

Speed Limiter

The stock OEM speed limiter will limit the vehicle to a top speed that is determined by the OEM. The vehicle speed limiter feature can be adjusted downward from the OEM position (around 98 mph) to limit vehicle top speeds. The results in field testing show that fuel is saved when top speed is limited.

Calibrate OEM Speedometer

Adding a different sized tire than the stock OEM tire size will cause the speedometer to read incorrect speeds. The Triple Dog E3 Downloader can calibrate the OEM speedometer to read correctly for many different tire sizes. This feature is available on most all of the vehicle applications.

DPF burn-off/ Mobile Desoot

This feature will send a request to the vehicle to move into a regeneration mode to burn off the Diesel Particulate Filter on the late model diesels that have the diesel particulate filter. This feature is only available for GM Duramax LMM and Dodge 6.7L Cummins.

Diagnostic Trouble Codes

The Power Pup can read and erase diagnostic trouble codes. Codes should be checked periodically and whenever a warning light appears on the vehicle dash. Visit: www.bullydog.com/DTC.php for trouble code meaning and interpretation. The trouble codes that are commonly seen on vehicles are described on the Power Pup screen, so it is not necessary for the end user to refer to the website.

HOW TO:

- **Install the Triple Dog E3:** The Triple Dog plugs into the OBDII port beneath your steering column for programming.
- **Transfer to a new vehicle:** Return current vehicle to stock, update the downloader online and check for new vehicle compatibility, and then install on new vehicle.
- **Update Online:** Internet updates are made available when new calibrations are developed and when new vehicle applications become available. Internet updates are available through our download center. Vehicle must be downloaded back to stock before the downloader can be updated. To access the latest updates visit www.bullydog.com/Download_Center.php, the Bully Dog Download Center.



BULLY DOG

Triple Dog E3 Diesel (part 40505) Applications

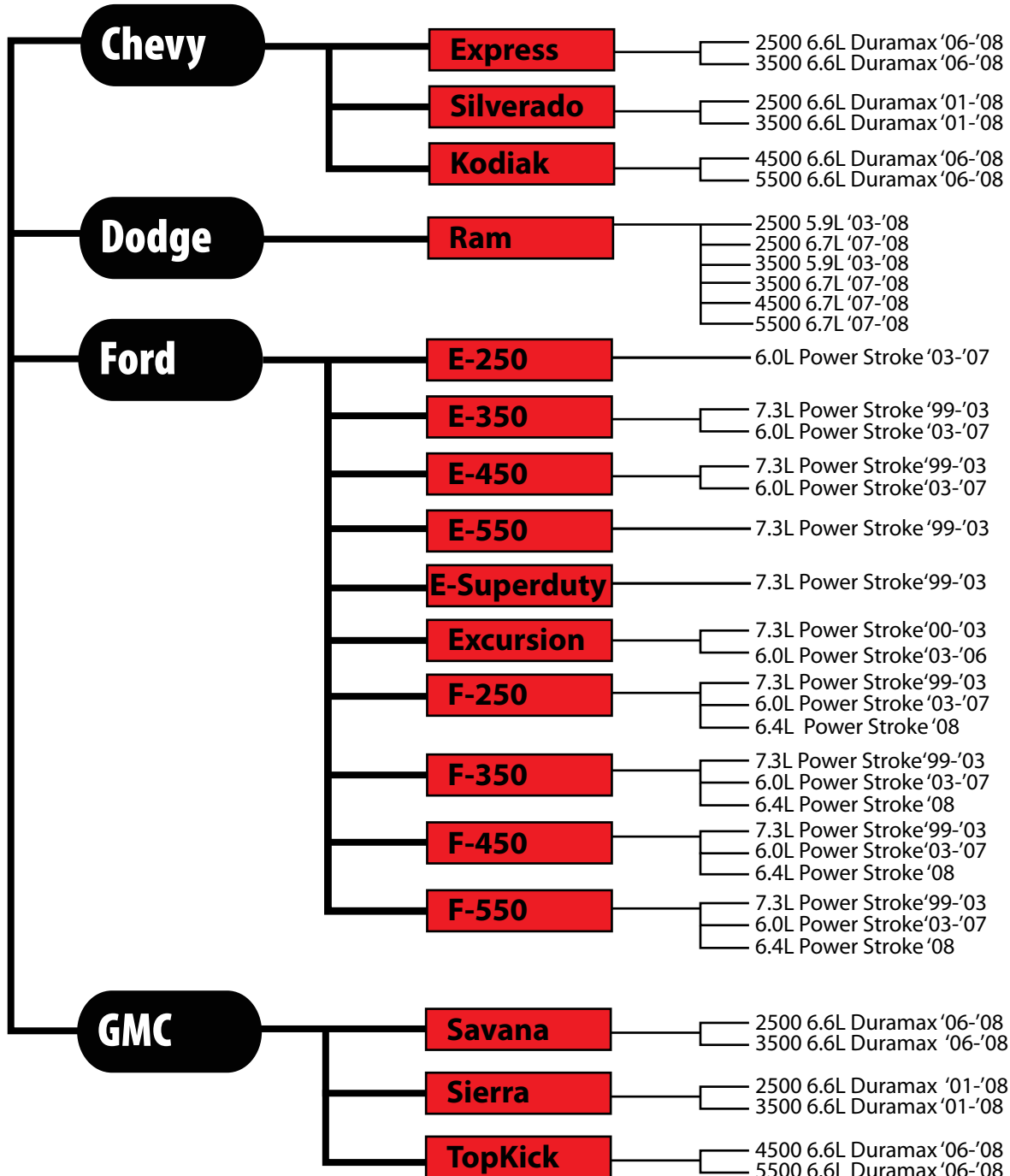

PRODUCT INFORMATION SHEET